

Imagicor!

By Designed Images

Fabrication & Installation Manual

2005

Contact: Renée Hoenigman
10121 Stafford Road Unit C, Chagrin Falls Ohio 44023
Phone: 440-708-2526 - Fax: 440-708-0714
e-mail: thoe@designedimages.net

Table of Contents

Introduction3

Warranty Information4

Required Tools & Supplies5

Critical Fabrication Rules6

Storage and Safety Precautions7

Fabrication Principles8

Fabrication Techniques9

Cleaning Care21

Quality Assurance Checklist22

Handling/Fabrication/Flexible Grade24

Specifications26

Introduction

Designed Images' *Imagitor*TM standard grade are thermoplastic polymer products that have the reflective gloss and beauty of hand lacquered surfaces. Their deep surface visuals combined with their high gloss finishes make these products one of the most elegant, practical, stain resistant decorative surfacing materials on the market today.

Imagitor has a highly polished appearance, which makes them the ideal material to use for vertical interior applications, including fixtures and furniture, cabinetry and millwork, casegoods, wall treatments and signage.

Imagitor is available in solid, metallic and pearlescence colors.

To determine the grade to use for your particular applications, refer to Table 1, below.

THICKNESS	MATERIAL	BENDING RADIUS
.118"	Acrylic	Cold 18"
.060"	Acrylic	Cold 9" Hot 6" **
.060"	Polycarbonate	Cold 6"
.030"	Polycarbonate	Cold 3"

Table 1

** Heating blankets should be used in this application.

This manual is written primarily to assist fabricators and installers in the best techniques to use when working with Designed Images' *Imagitor*. Architects, interior designers and builders will also find valuable product information to help them take full advantage of this innovative product.

The fabrication techniques discussed in this manual are very straightforward. **However, because of the unique attributes of polymers, Designed Images strongly recommends that you read this manual before you begin working with these products.**

You must take caution when performing some of the steps and ensure that you follow all the critical techniques discussed in the manual.

Before starting a job, use a 2' x 4' trial piece of *Imagitor* to learn about and become familiar with the products' characteristics.

NOTE: *Imagitor* should not be used for kitchen countertops or other high wear applications.

Warranty Information

LIMITATION OF WARRANTY AND LIABILITY

Limited Warranty: Seller warrants that the products sold shall be of merchantable quality and shall conform to Seller's standard specifications. Buyer assumes all risk as to the results of the use of the products purchased, whether used singly or in combination with other materials or in any process.

Limitation of Claims: At Seller's option, Seller will replace, without additional charge, products which do not comply with the warranty or, upon return of the products at Seller's expense, refund the purchase price.

Seller makes no warranty, express or implied, based on any course of dealing or usage of trade or of fitness for particular use or otherwise, other than that stated herein or required by applicable law. Seller's liability for any loss or claim whatsoever, including a claim for breach of the warranty merchantability, shall be limited solely and exclusively to replacement of defective or non-conforming products or, at the election of seller, to return of the products and repayment of the purchase price. In no event shall seller be liable for any other actual damage or any special, incidental, consequential or exemplary damages.

Buyer is responsible for inspection of the product upon receipt and prior to any cutting or fabrication. Any claim by Buyer for breach of warranty shall be deemed waived to the extent it could have been determined by such inspection, unless presented in writing to the Seller within ten days from the day of receipt of the products to which such claim relates. In all events, claims not made within two months after receipt are deemed waived. Products are shipped with a protective film to protect product during transit and storage. All such products must be inspected for defects prior to cutting or fabrication. Surface must then be protected during cutting and fabrication. Failure to remove the protective film to inspect for defects prior to cutting or fabrication is at Buyer's risk.

Any question concerning this warranty should be directed to: Designed Images, Inc., 10121 Stafford Road, Unit C, Chagrin Falls, OH 44023 – 440-708-2526.

Required Tools & Supplies

There are tools and supplies that are specifically designed for fabricating decorative Acrylics and Polycarbonates. However, most of the tools and supplies that are required are usually found in a professional cabinet shop.

- ▶ Orbital (palm) sander – 10,000 rpm or more
- ▶ Routers: 7/8 to 1-3/4 HP – more powerful routers will damage the material
- ▶ Carbide router bits with ball bearing guide
 - 1) Flush for trimming or sizing (2 or 3 flute)
 - 2) 45° and 22-1/2°, 2 flute chamfer bit or a 1/8” radius roundover bit
- ▶ Heavy-duty electric drill – at least 2400 rpm
- ▶ Polishing & buffing wheels
 - 1) 4” cotton polishing buffs
 - 2) 3” polishing wheel with 1/2” arbor and 1/4” shank
- ▶ Polishing Compound
 - 1) Disco Buffing Composition
 - 2) Novus Plastic Polish (1,2,3)
 - 3) 3M Finesse-it™ Plastic Polish
- ▶ Circular carbide tip blades
 - 1) Triple chip grind with minimum carbide overhang
 - 2) 12” x 100 tooth with 1 - 5° positive rake
 - 3) 10” x 80 tooth with 1 - 5° positive rake
- ▶ Sandpaper
 - 1) 120 grit (80 microns)
 - 2) 220 grit (60 microns)
 - 3) 320 grit (40 microns)
- ▶ Edgebanders

Set the trimmer on your edgebander for the accurate thickness and check the automatic feed roller. If you have a prick roller, feed the sheet through the edgebander by hand to prevent puncturing the back of the sheet.
- ▶ Adhesives

Use only water based adhesives on decorative acrylics. Translucent (non-pigmented) adhesives produce an inconspicuous glue line, which provides the best results. **Do not use pigmented adhesives (green, red, etc.).**
- ▶ Cleaners
 - 1) Non-ammoniated cleaners
 - 2) Windex® with Vinegar D
 - 3) SOS™ Glass Cleaner with Vinegar
 - 4) Like Magic Type N1-5
 - 5) Tend-Anti static Cleaner
 - 6) Metrix Anti-Static #79 Cleaner
 - 7) Kleenmaster® (Brilliance)
 - 8) Chemprize Repel
 - 9) Soft Cloth or sponge with mild soap and water.
 - 10) Micro-Pel®

Do not use alcohol or solvent based cleaners for they can craze the acrylic.

Critical Fabrication Rules

- 1) Cut sheets from the back (face down) to protect the back from damage.
- 2) Precondition all materials (decorative acrylic, substrates, laminate and adhesives) to the same temperature and humidity for a minimum of 48 hours before fabrication.
- 3) Use a high quality medium density fiberboard (MDF) or particleboard. Do NOT apply directly to plastered walls, gypsum, wallboard or concrete walls.
- 4) Apply water-based adhesives lightly and evenly (spraying is preferred). The adhesive should dry on both the decorative acrylic and the substrates before laminating. In order to prevent blistering or delamination, do NOT let the adhesive “skin over”, entrapping moisture from water-based adhesives.
- 5) Use VMP Naptha or mineral spirits to remove excess adhesive. Do NOT use alcohol or solvents, such as lacquer thinners, acetone, MEK, toluene and methylene thylene chloride, since these attack the decorative acrylic and cause delamination.
- 6) Keep laminated sheets intact after adhesive is applied. Moving or pulling a laminated sheet apart after lay up adversely affects the back of the decorative acrylic sheet.
- 7) Prevent stress cracks by fabricating a 18” minimum radius for .118” grade and a 9” maximum radius for .060” bending grade material, cold. To fabricate a 6” minimum radius using .060” material, you must use heat to prevent stress cracks. All radiuses must have a minimum 2” tangent.

NOTE: When bending Imagitor™ standard grade, you are inducing stress in the sheet. Rough cuts (chips or nicks) on the edges are stress risers and failure (stress cracks) is possible. Clean the edges to remove all chips and nicks that resulted in cutting pieces to size on a table saw.
- 8) Use a router to flush trim inside cutouts and round all the 90° angles to prevent stress cracking and chipping. A minimum 1/8” radius is recommended. Please note that a 1/4” router bit produces a 1/8” radius on a 90° inside corner cutout.
- 9) Sand all edges to remove chatter that can cause stress cracking. Polish all edges to bring out the product’s full depth and appearance.
- 10) Use soap and water, non-ammonia glass cleaner or vinegar for routine cleaning. A soft white 100% cotton cloth, such as a t-shirt or towel, or a sponge should be used to wipe surfaces.
- 11) Leave protective covering on the decorative surface through final installation.

Storage and Safety Precautions

Storage Precautions

Imajicor™ sheets are covered with a clear masking that protects the sheet from dirt and moisture. While the sheets are stored, the masking must be left intact to prevent scratching the surface of the material.

Store the sheets vertically in a covered A-frame rack at an angle of approximately 10°.

If it is necessary to store sheets horizontally, leave them in the carton. If the sheets are out of the carton, stack the larger sheets at the bottom to avoid sagging or unsupported overhang.

Prevent the masking from tearing to keep dirt from scratching the acrylic sheets.

In addition, you must take the following precautions:

- Do NOT store the sheets near radiators, steam pipes or other heat sources, since heat can soften and deform the sheets.
- Do NOT store sheets near spray painting booths.
- Do NOT expose sheets to solvent vapors, which may penetrate the protective peel masking and damage the sheet's surface.

Safety Precautions

Work in a well ventilated area. Cutting, routing, sanding and edge buffing generate nuisance dust. Use tools with dust collectors and wear a dust mask.

Always wear eye protection when cutting, sanding or routing.

Use care when handling Imajicor sheets – sharp or burred edges can cause cuts.

Fabrication Principles

ADHESIVES

Water Base Contact Cements

With water base cements, most of the water must evaporate (flash off) before laminating. If the adhesive is not completely dry before laminating, a strong bond is not created and delamination may occur. In addition, most water base adhesives have low levels of solvents and can blister if not properly dried (flushed).

The drying time for water base contact cements is affected by variations in atmospheric/humidity conditions. Manufacturers' recommended open and set-up times do not take these conditions into account. **As a result, it is up to you to ensure that the adhesive on the decorative sheet and the substrate is completely dry before laminating.**

Before using an adhesive for full scale production, Designed Images recommends testing it to determine its suitability for specific projects and operating conditions. Contact your adhesive supplier for specific recommendations, product data and material data safety sheets.

Bonding

Properly applying adhesive to the back of the decorative acrylic and the substrate is critical to the success of the project. Spraying provides the best results. When adhesive is brushed or rolled, it may be applied too heavily. Heavy application of adhesives can cause skinning, where water does not evaporate (flash off). This, in turn, can cause blisters or delamination. After applying the adhesive, check to make sure there are no blobs or heavy build-up. Make sure the adhesive is applied evenly, since an uneven application causes a thick glue line, which is noticeable on the seam.

When the adhesive on the decorative sheet and the substrate is dry, laminate the two together. To ensure a strong bond, apply pressure evenly across the sheet with a J-roller or squeeze roller. Applying pressure with your hand does not ensure a tight bond, especially on large wall panels.

Fabrication Techniques

There are three different methods you can use to build Imagitor panels. The different types of panel construction, their descriptions and how they are rated according to structural soundness, labor and material costs are shown in Table 1, below.

To avoid confusion and eliminate repetitive steps, this manual only describes the steps for Semi-Balanced Construction.

Designed Images does not warranty the material used for substrates or the adhesives.

Description	Acrylic Back	High Pressure Laminate (HPL) Back	MDO Plywood
Construction	Balance Composition	Semi-Balanced Composition	Semi-Balanced
Front	.118" Imagitor	.118" Imagitor with .050" Backer Sheet	.118" Imagitor
Middle	5/8" Substrate	5/8" Substrate	5/8" to 3/4"
Back	1/8" Acrylic	.048" HPL	
Structural Soundness	High	Moderate/High	Moderate/Low
Labor Costs	Moderate	High	Moderate
Material Costs	Moderate	Moderate	Low

Table 1 – Panel Construction Description and Ratings

Fabrication Techniques

Follow the steps described in this section to build an *Imagitor* panel. If you decide to use a method other than the Semi-Balanced Construction, you may skip some of the steps, when noted in the text. Make sure all materials are stored for at least 48 hours at the same temperature before they are exposed to extreme temperature and humidity changes.

CUT PANELS

Use a saw with a circular carbide tip saw blade to cut the right size panels and strips. **Make sure the decorative material is face down when cutting.** See Figure 1.

Leave a 1/8" to 1/4" overhang on both the panels and strips to allow flush trimming.

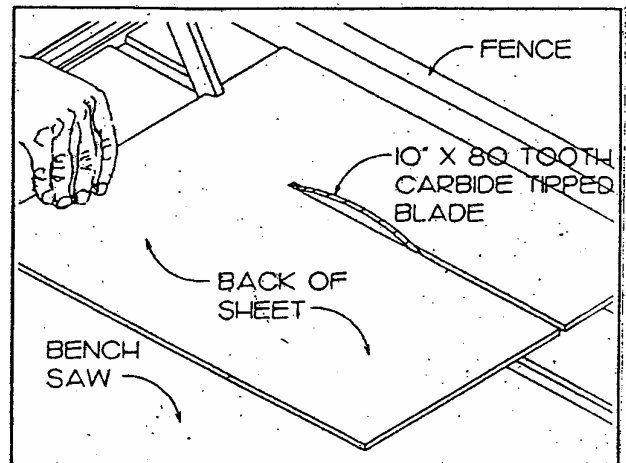

Figure 1

ADHERE BACKER/BACK SHEETS

1. Apply adhesive to the substrate facing and the .050 backer sheet and adhere them together. (The substrate used between the *Imagitor* sheet and the backer sheet must be sanded on both sides.)
2. Apply adhesive to the facing side of the substrate and the back side of the .050 decorative laminate and adhere them together.

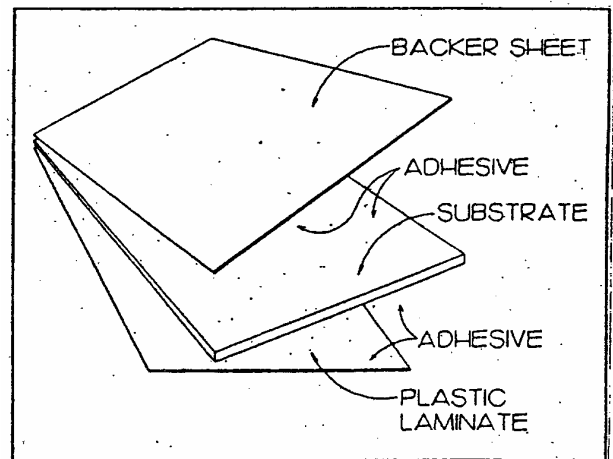

Figure 2

See Figure 2.

Skip this step if you are using another construction method.

Fabrication Techniques

APPLY EDGES

1. Apply adhesive to the edge strip material and to the substrate edges. See Figure 3.

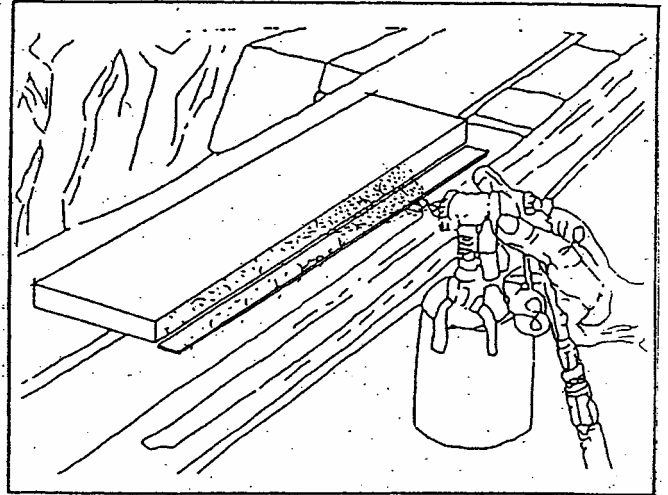

Figure 3

2. Adhere the edge strips to the substrate by hand, using a J-Roller or a high quality edgebander (no pricks). If you use an edgebander, set its trimmer for the accurate thickness and check the automatic feed roller. A prick roller can puncture the back of the sheet, therefore, feed the sheet through the edgebander by hand. You can also use hot melt adhesive with an edgebander. See Figure 4.

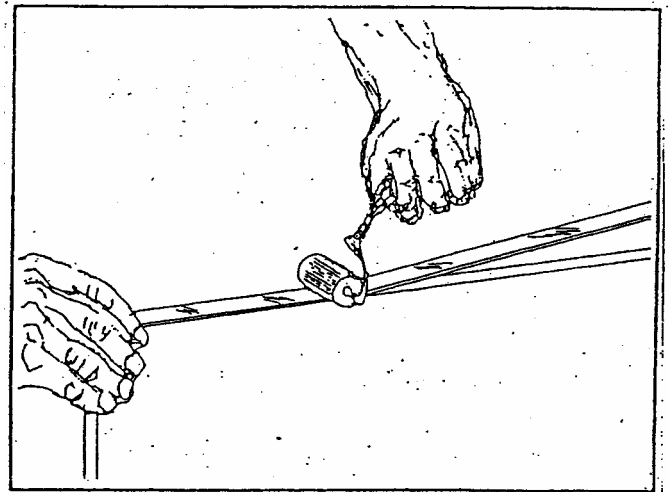

Figure 4

3. Use a router bit with a 2 or 3 flute cutter head with a ball bearing guide to flush trim the strips to the edge of the substrate. See Figure 5.

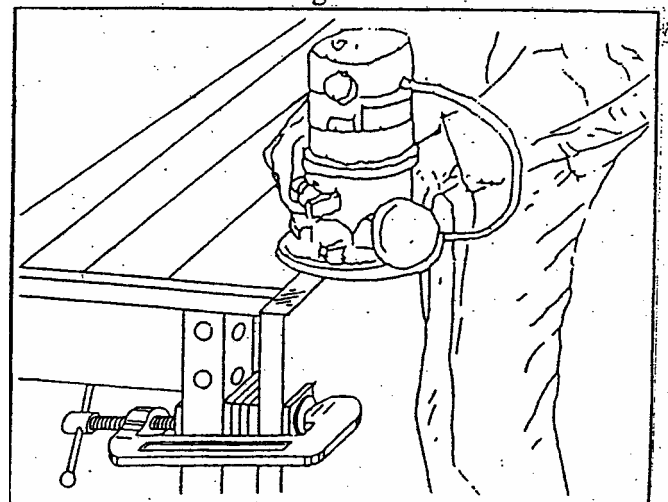

Figure 5

Fabrication Techniques

4. Lightly sand the front and back edges to ensure the strips are even with the substrate. See Figure 6.

Make sure you do not scar or mar the decorative sheet on the backside.

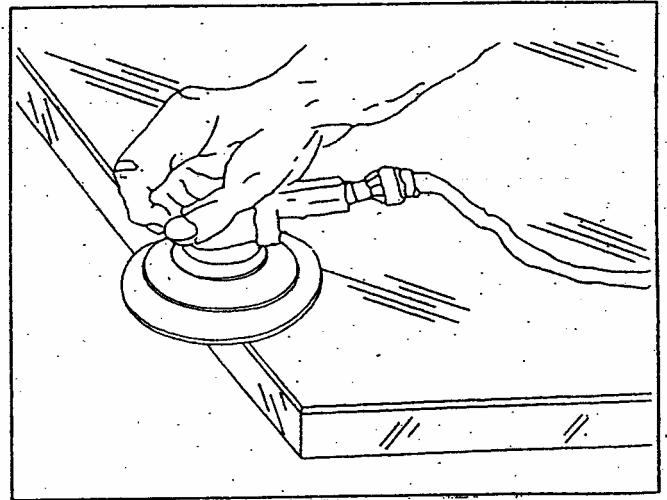

Figure 6

APPLY Imagicor's FACING TO SUBSTRATE

1. Do not remove the protective film from the decorative side of the Imagicor sheet.
2. Spray or roll the adhesive on the substrate facing and back of the Imagicor panels. Remember, the adhesive must be completely dry before laminating the decorative acrylic panel to the substrate. NOTE: Water based adhesive has a high solid content compared to solvent based adhesive. A very light coat of water based adhesive is sufficient. See Figure 7 & 8.

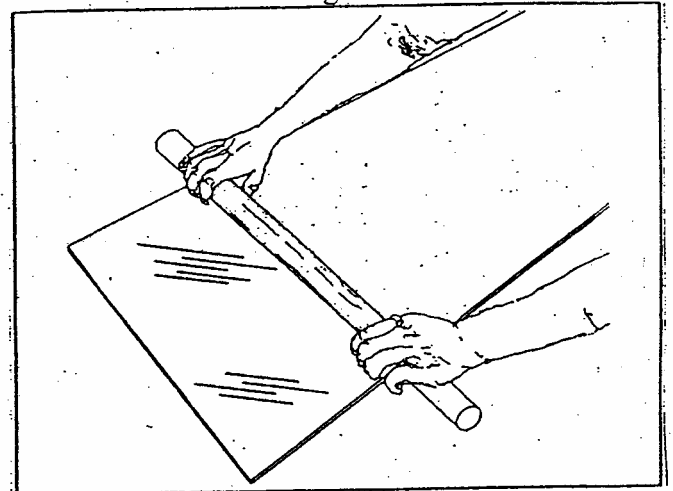

Figure 7

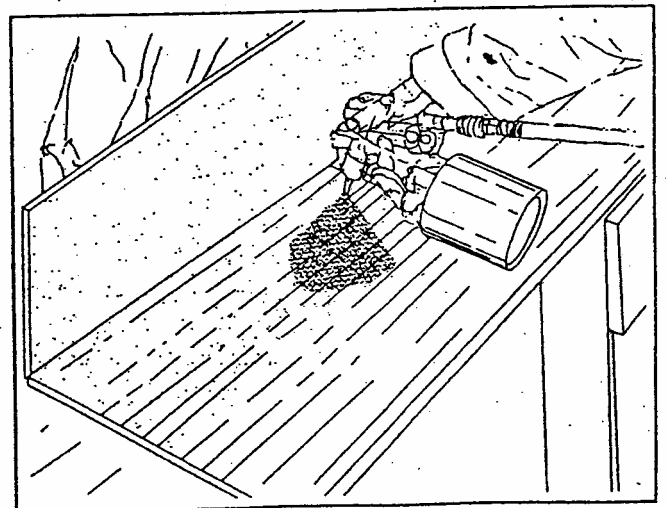

Figure 8

Fabrication Techniques

- 3. Adhere the Imagior face panel to the substrate. See Figure 9.

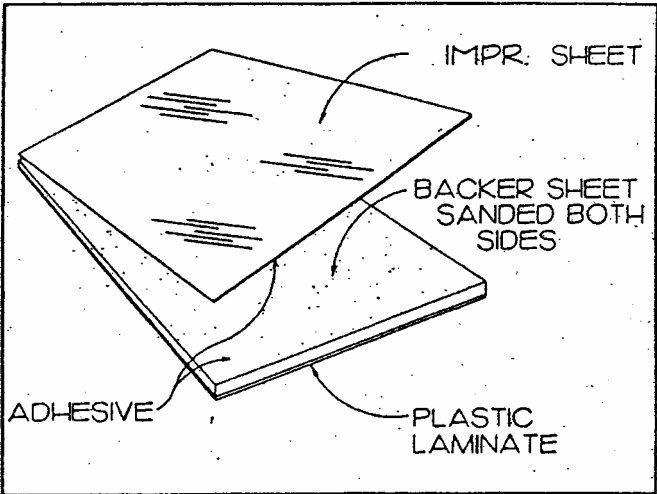

Figure 9

- 4. Flush trim the overhand using a router with a 2 or 3 flute trimming bit. See Figure 10.

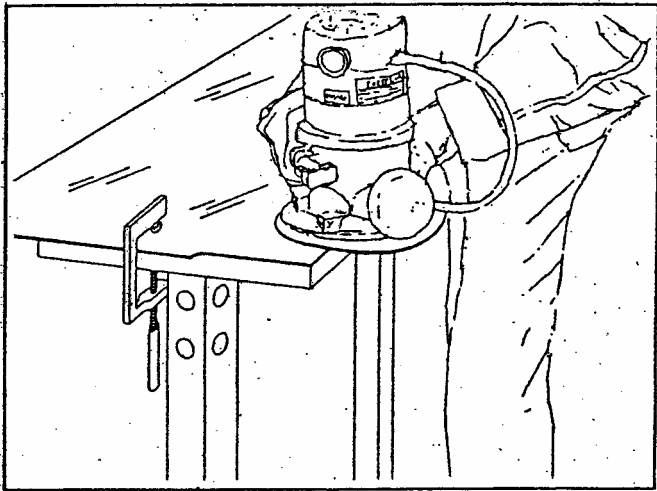

Figure 10

Fabrication Techniques

PROFILE EDGES

The ability to create a smooth, highly polished profile edge is one of the many advantages *Imagitor* provides over other materials. Profiling an *Imagitor* edge involves routing, sanding and polishing/buffing to produce a clear, high gloss finish.

DO NOT SKIP ANY OF THE STEPS LISTED BELOW.

ROUTING

When routing, you must use a router bit with a ball bearing guide.

1. Rout the edges using a flush-cut router carbide bit. Because of its thickness, decorative acrylic takes more time to rout than laminates, therefore do NOT rush. See Figure 11.

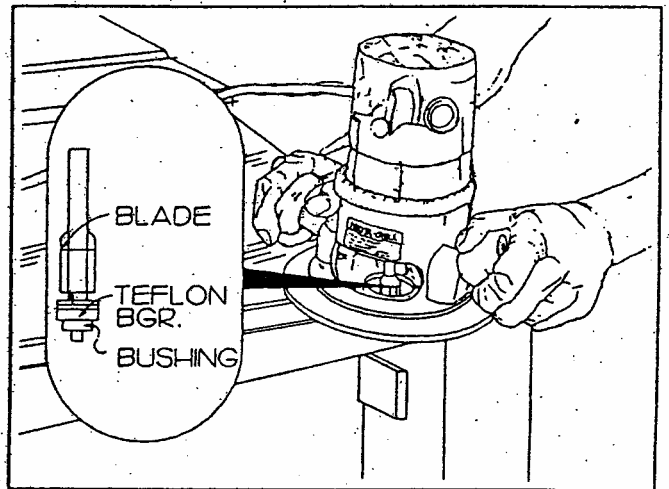

Figure 11

2. Bevel edges using either a 22-1/2° or 45° carbide, 2 fluted chamfer profile router bit or a 1/8" radius roundover bit. Use a bit that is the same thickness as the *Imagitor* sheet. See Figure 12

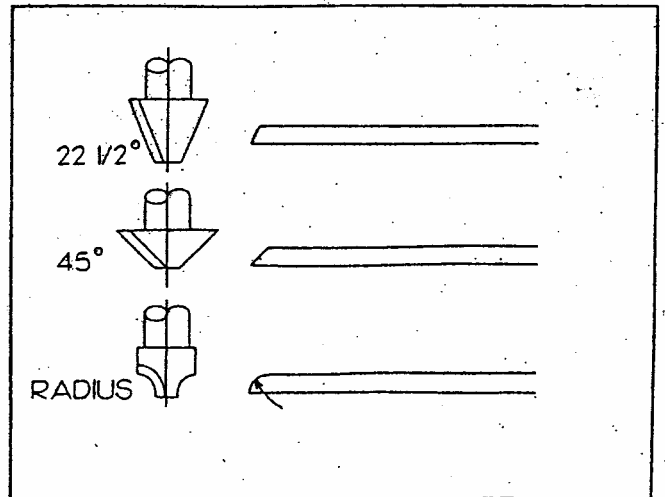

Figure 12

Fabrication Techniques

SANDING

1. Peel the protective masking away from the edge before sanding.
2. Use a 10,000 RPM dual action or orbital sander with a hard or stiff sanding pad. If there is a lot of router chatter, follow the sanding sequence below. However, if there is only a small amount of chatter, you can skip sanding with 120 grit and go straight to the second sanding step. See Figure 13.
 - a. Sand using 120 grit or 80 micron paper. Clean and wipe off edge.
 - b. Sand using 220 grit or 60 micron paper. Clean and wipe off edge.
 - c. Sand using 320 grit or 40 micron paper. Clean and wipe off edge.
3. Rub the edge with a cloth dampened with water to highlight chatter marks.
4. Repeat the sanding steps, described above, until all chatter marks are completely removed.

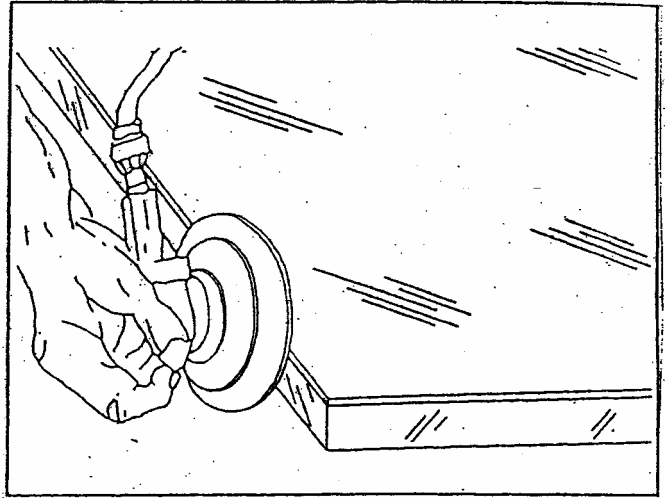

Figure 13

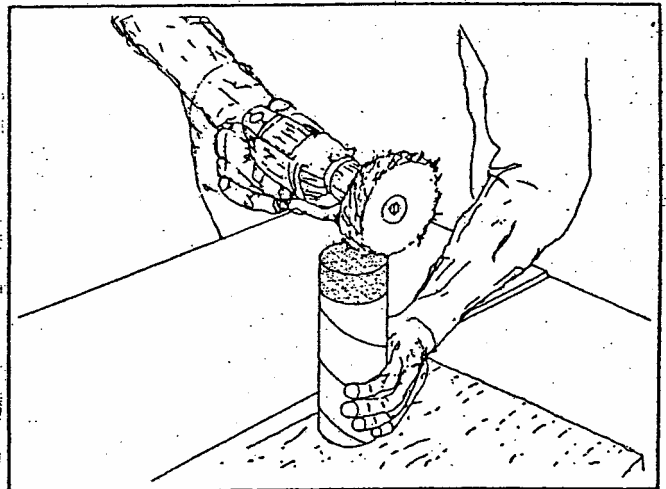

Figure 14

POLISHING/BUFFING

1. Apply the polishing compound to the buffing wheel. See Figure 14.
2. Buff until sanding marks are completely removed and the beveled edge is polished to a high gloss. See Figure 15.
3. Remove the excess polishing compound with a clean cotton buffing wheel.

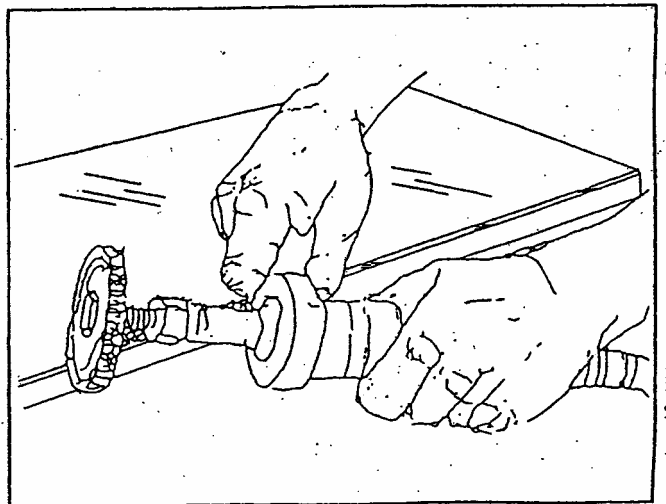

Figure 15

Fabrication Techniques

DRILLING

To attach hardware to an *Imagicor* panel, drill holes with a carbide drill bit that is designed specifically for acrylic and that has a sharp 60° to 80° angle. While a standard high speed drill bit can be used, a drill bit that a 60° angle is the best since it goes into the material gradually, which prevents chipping.

REMEMBER DRILL HOLES SHOULD ALWAYS BE A MINIMUM OF 1/16" LARGER THAN THE SCREW. DRILL HOLES THAT ARE THE SAME SIZE OR SMALLER CAUSE CRACKING.

See Figure 16.

YOU MUST FOLLOW PROPER DRILLING TECHNIQUES TO PREVENT IRREGULAR HOLES, CHIPPING OR MELTING.

1. Clamp or hold the decorative panel firmly to a worktable to provide support. Supporting the decorative acrylic panel prevents a blow out when the drill exits the material.
2. Use any commercially available portable drill, drill press, or automatic multiple-spindle drilling unit fitted with a drill bit that has a sharp 60° angle to prevent chipping.
3. Drill, using a slow feed rate at first to let the bit gradually enter the material. This prevents chipping.
4. Slow the feed rate when the bit exits the bottom surface to prevent chipping.
5. Insert the screw, making sure not to over tighten. Over tightening the screws may cause cracking. See Figure 17.

SCREW SIZE	DRILL BIT SIZE
1/8"	3/16"
3/16"	1/4"
1/4"	5/16"
5/16"	3/8"
3/8"	7/16"

Figure 16

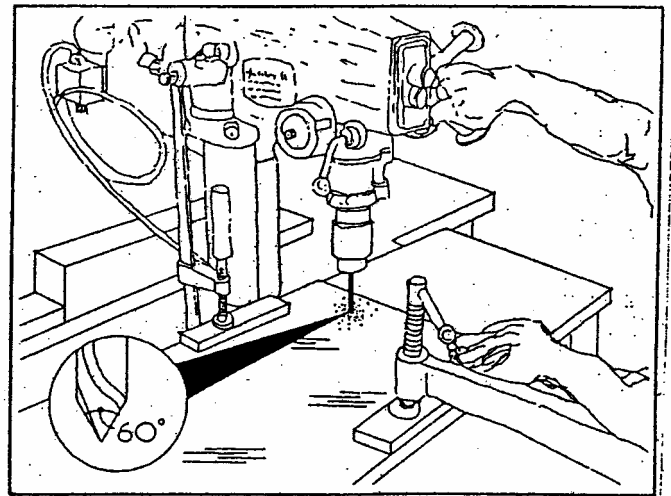

Figure 17

Fabrication Techniques

MAKING INSIDE CUTS

Inside cuts are used in bookshelves, wine racks, electrical outlets, picture frames and cabinet face frames.

To make inside cuts, follow these steps:

1. Cut or drill a pilot hole into the decorative acrylic. Make the hole large enough to accommodate the router.
2. Make the appropriate size cutout with a router.
3. Round out all 90° angles to an 1/8" radius, minimum, to prevent stress cracking and chipping.

See Figure 18.

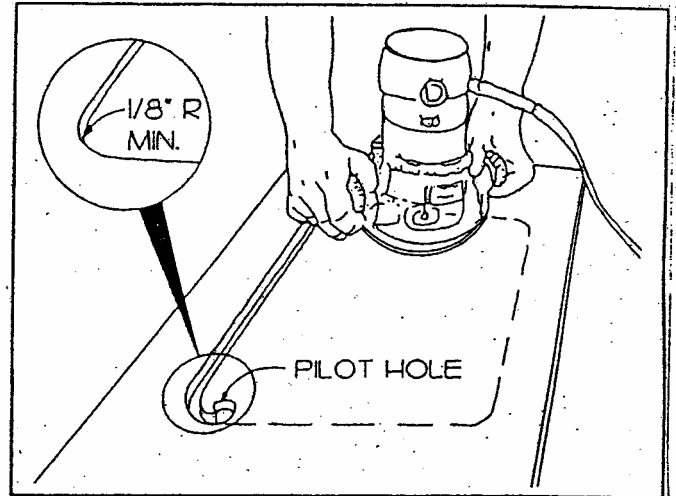

Figure 18

SEAMING

When joining decorative acrylic sheets, use either a V-Groove edge or a Strip/Reveal edge. Flat seams and butt joints are not recommended for decorative acrylics, since it is impossible to eliminate slight variances in thickness between sheets.

REMEMBER TO LEAVE THE PROTECTIVE MASKING ON THE DECORATIVE SURFACE OF THE ACRYLIC SHEETS.

V-Groove Bevel Edge

1. Paint the substrate joint with a marking pen to camouflage the seam. See Figure 19.
2. Cut and bevel the Imagecor edges with a router. Refer to the Routing section under Profile Edges on page 13.
3. Perform the three-step sanding procedure according to the instructions in the Sanding section under Profile Edges on page 14.
4. Polish/buff edges, following the steps on page 14.
5. Apply contact cement to both surfaces. Let it dry.
6. Adhere sheet to substrate leaving a 1/16" gap between the two polished edges of the two sheets. See Figure 20.

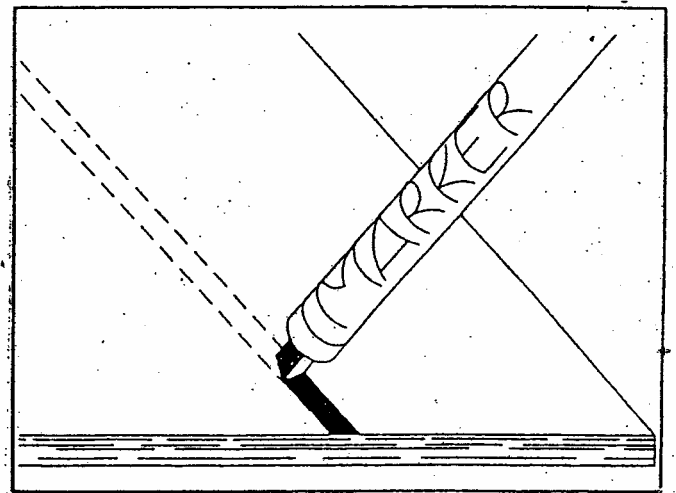

Figure 19

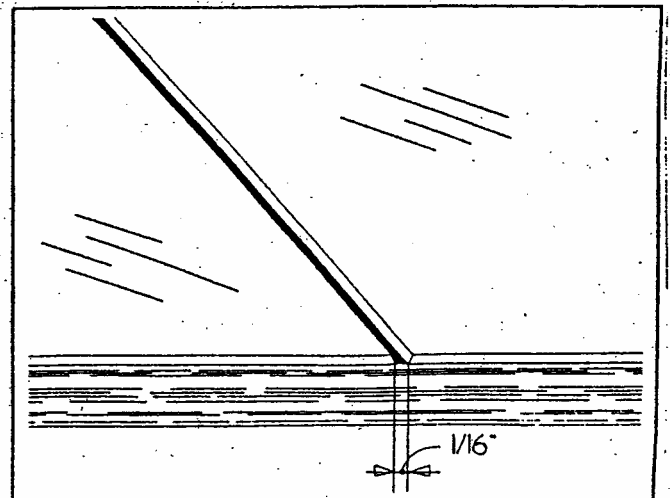

Figure 20

Fabrication Techniques

STRIP/REVEAL WITH BEVELED EDGE

1. Apply adhesive to the panels and the substrate. Let it dry.
2. Adhere the panels to the substrate, leaving a $1/16''$ gap between the two sheets.
3. Cut a strip the length of the seam.
4. Rout a $22-1/2^\circ$, 45° or radius roundover edge on each side of the strip using the appropriate bit.
5. Sand and polish all edges on the strip according to the instructions in the Sanding section under Profile Edges on page 14.
6. Apply silicone onto the back of the strip reveal and place it over the gap. Apply masking tape over the strip reveal to hold it in place until the silicone sets.

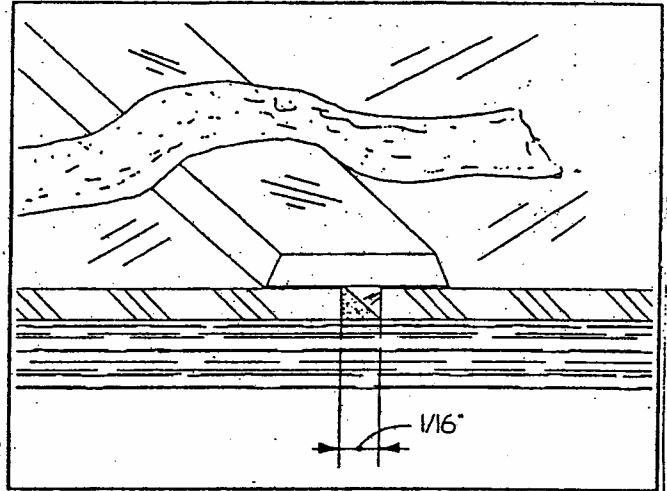

Figure 21

See Figure 21.

Fabrication Techniques

BENDING RADII

The grade and size of the decorative acrylic sheet determines the type of radius bending method you use.

The radius limits are as follows:

Material	Method	Radius	Distance Beyond Tangent
.118 Grade	Cold Bend	18"-20"	2" or greater
.060 Grade	Heat Bend	6"	2" or greater
.060 Grade	Cold Bend	9"	2" or greater
.030 Grade	Cold Bend	3"	2" or greater

See Figure 22.

COLD BEND METHODS

Follow these steps to fabricate radii.

1. Cut panels or strips 1/16" oversize.
2. Rout or file cut edges to eliminate cracking caused by the bending process.
3. Work in sections. Bend the decorative acrylic by extending the sheet past the radius onto a flat beyond the tangent by to 2".
4. Apply adhesive lightly and evenly only to the surface of the section you are working on and clamp into place.

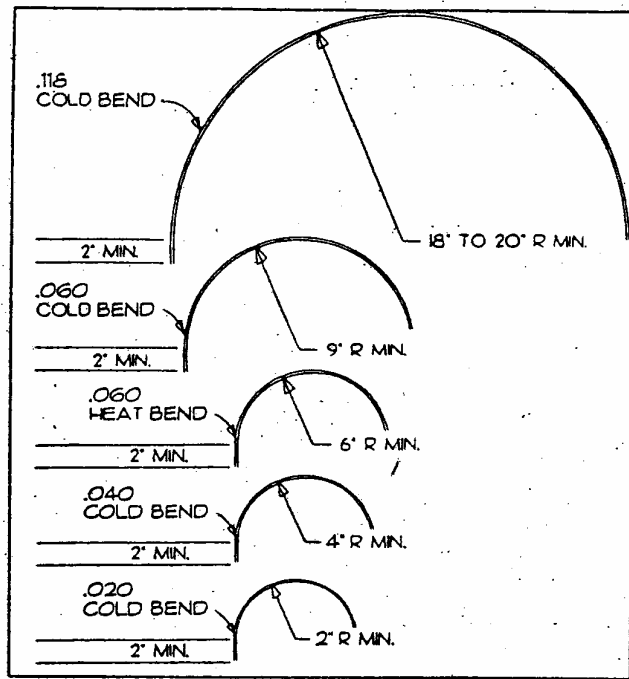

Figure 22

HEAT BEND METHODS

You must apply consistent heat (190° to 210° F) to the surface area of a panel when creating a radius. The larger the panel the more important it is to use the proper heating equipment. For example, to create a 6" radius from a 3'W x 5'H panel you must use heating equipment, such as blankets or ovens.

1. Practice with a 2' x 4' sheet of decorative acrylic before using heat to create the radius on your project.
2. Use the following heat methods to create a 6" radius:
 - a. Heat guns are recommended when the surface heating distance does not exceed 24". Distances beyond this point cause uneven heat distribution and may result in sheet pull back or cracking.
 - b. Silicone heat strips, available in the following range of sizes: 1"x51" to 6"x52"; provide the best surface heat consistency.
 - c. Heat ovens designed for solid surfacing or acrylics.
3. Prevent stress cracking after heat bending the radius by using a heat absorbing blanket to gradually cool down the decorative acrylic.

Fabrication Techniques

SURFACE REPAIR

You can easily repair minor scratches. However, deep scratches and scratches that cover the entire surface are extremely difficult to repair, especially on dark patterns.

After your project is completely fabricated, if you need to clean the surface and make repairs, follow these steps:

1. Remove the protective masking.
2. Inspect the surface for scratches. If there are no scratches, clean the surface with a soft white 100% cotton cloth or towel or a sponge and mild soap and water. A non-ammoniated spray glass cleaner may also be used. **DO NOT USE DENATURATED ALCOHOL OR AN ABRASIVE PAD.** (Refer to Cleaning Care on page 20.) See Figure 23.
3. Repair the minor scratches using a polishing compound such as 3M Marine Trade products. See Figure 24.
4. Wet sand scratches too deep for polishing by applying water and using a sanding disc to produce a smoother finish. **THE ACRYLIC OVERHEATS IF YOU ATTEMPT TO SAND WITHOUT WATER.** See Figure 25.

Sanding Disc

- P 400-255L – 5” stikit – if necessary (for very severe situations)
- P 600-255L – 5” stikit
- P 800-260L – 5” stikit

Then buff with Finesse-it II using a #5075 buffing pad (yellow). Hand apply Liquid Polish #5939 and hand remove.

Always work backwards when removing abrasions and very light scratches.

Example: Start with the liquid polish, if that does not work, go to the Finesse-it II, if that does not work go up the ladder to the next step. What you don't want to do is be over aggressive in removing scratches or abrasions. This will cause you unnecessary time and labor to restore the finish to its original luster.

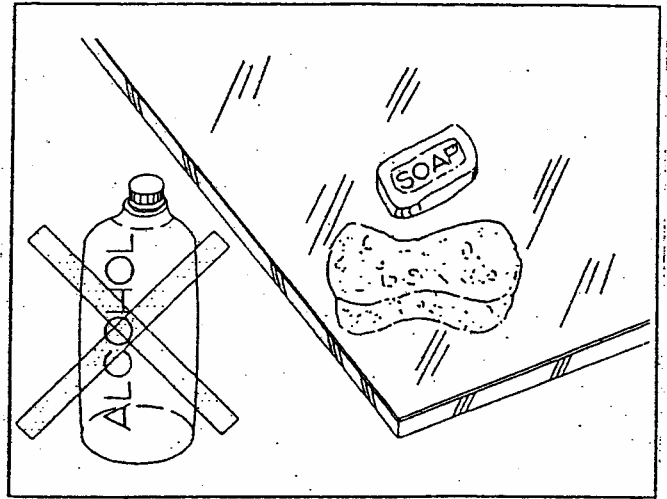

Figure 23

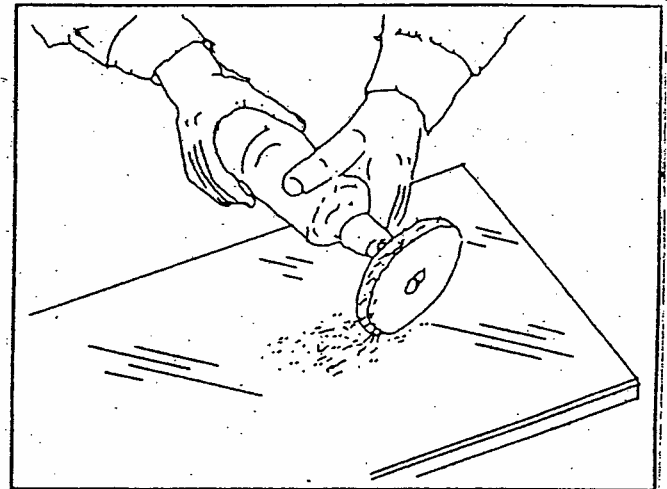

Figure 24

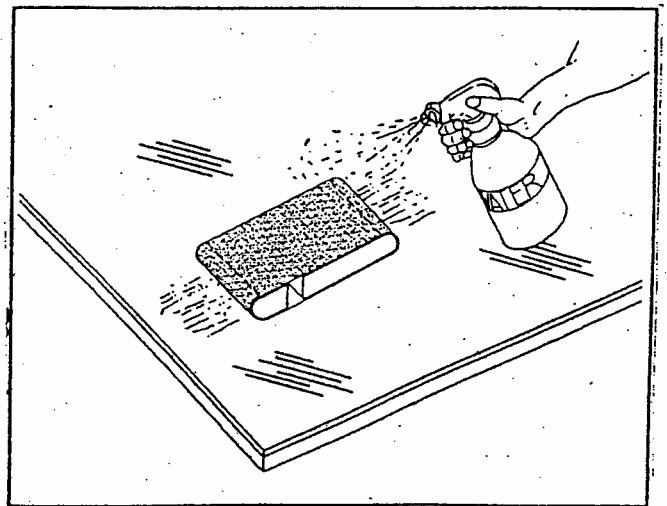

Figure 25

Cleaning Care

CLEANING CARE

Use a soft white 100% cotton cloth or towel, or a sponge, and milk soap and water to clean decorative acrylics. A non-ammoniated spray glass cleaner, such as Windex® with Vinegar D by Drackett Products, S.O.S.™ Glass Cleaner and Vinegar Glass Works by Miles, Inc. may also be used. **Never** use nylon or polyester blend cloths, paper towels, abrasive pads or abrasive cleaners since they will scratch the surface.

To prevent damage to the entire surface, test the cleaner on an unobtrusive area using the same concentration and technique planned for the entire job.

Quality Assurance Checklist

FABRICATION STEPS	KEY ITEMS	POTENTIAL PROBLEMS
Applying to Substrate	<p>Use No. 1 grade A MDF, No. 1 or grade A, minimum 45 lb., particleboard.</p> <p>Precondition substrate, adhesives, Imagitor and laminate for 48 hours at the same temperature and humidity (78° and 45% relative humidity.)</p> <p>Do NOT apply material to plastered walls, gypsum, wallboard or concrete.</p>	<p>Warping from low grade substrate or failure to precondition all materials.</p>
Cutting Material	<p>Cut the sheet with the decorative side face down.</p> <p>Use 10" x 80 tooth or 12" by 100 tooth, 0 to 5° positive rake, C4 carbide, triple chip grind blade.</p>	<p>Blow out, cracking.</p>
Bonding	<p>Use water base adhesives only.</p> <p>Remember, drying times are affected by variations in atmospheric/humidity conditions.</p> <p>Spraying adhesives is preferred.</p> <p>Spray adhesive evenly on both the Imagitor and the substrate.</p> <p>Make sure the water base adhesives dry before bonding.</p> <p>Apply pressure with a 3" J-roller to ensure a strong bond.</p>	<p>Delamination with no coating separation indicates poor adhesive bond.</p> <p>Skinning can occur when adhesive is applied too heavily when water does not evaporate (flash off). This, in turn, can cause blisters or delamination after the job is installed.</p>
Finishing Edges	<p>Trim edges with flush cut/router carbide bit (2 or 3 flutes).</p> <p>Profile edges with 45° or 22-1/2°, 2 flute carbide chamfer bits or 1/8" roundover carbide bit.</p> <p>Sand edges to remove chatter marks: 1st pass – 120 grit/80 micron; 2nd pass – 220 grit/60 micron; 3rd pass – 320 grit/40 micron.</p> <p>Polish edges using a plastic polishing compound until sanding marks are removed. Buff the excess compound with clean buffing wheel to a higher clear gloss.</p>	<p>Unbeveled edge may cause stress cracks.</p> <p>Unfinished rough edges will crack.</p>

Quality Assurance Checklist

FABRICATION STEPS	KEY ITEMS	POTENTIAL PROBLEMS
Drilling & Mounting Hardware	<p>Drill holes at least 1/16" larger than the screw.</p> <p>Use drill bits with a sharp 60° to 90° angles to prevent slipping.</p> <p>Do NOT over tighten screws.</p>	Stress cracks can occur if the drill hole is too small.
Making Inside Cuts	Round out all 90° angles to a 1/8" radius.	Stress cracks can occur in 90° angles that are not rounded.
Seaming	<p>Join V-groove edges or strip/reveal edges. Do NOT attempt to fabricate flat seams and butt joints.</p> <p>Leave a 1/16" gap between edges.</p> <p>Camouflage gap with matching paint or marking pen.</p>	<p>Cracking or delamination due to expansion & contraction of the material.</p> <p>Thickness variation of material produces uneven seams, if flat seams or butt joints are used.</p>
RADIUSING	<p>Use proper technique for each grade of material.</p> <p>Extend material beyond 2" tangent.</p> <p>Heat material to 190° to 210° maximum temperature.</p> <p>Use ovens for large panels.</p> <p>Bend with male-female wooden molds.</p> <p>Use a heat absorbing blanket to cool down material for at least 15 to 20 minutes.</p> <p>Use silicone heat strips (recommended) or heat guns for areas no greater than 24" long and 6" wide. Cool down material for at least 15 to 20 minutes using a heat absorbing blanket.</p> <p>Apply heat for concave panels that do not exceed beyond 9" radius.</p>	<p>Delamination or cracking can occur if the recommended radius is exceeded.</p> <p>Stress cracking can occur if material is under heated.</p> <p>Delamination can occur if material is over heated.</p> <p>Stress cracking from too rapid cool down.</p>
Cleaning & Maintenance	<p>Use a soft white 100% cotton cloth or towel or a sponge. Do NOT use paper towels, nylon or polyester blend cloths or towels or abrasive pads.</p> <p>Use mild soap and water or a non-ammoniated spray glass cleaner such as Windex Vinegar D or S.O.S. Glass Cleaner Vinegar.</p> <p>Remove minor scratches with a plastic polish such as Novus Plastic Polish or 3M Finesse-it.</p> <p>Remove fingerprints with anti-static cleaners such as Kleenmaster (Brilliance), Like Magic Type n1-5, or Novus.</p> <p>Remove glue with VMP Naptha or mineral spirits.</p>	<p>Abrasive materials and pads will scratch.</p> <p>Ammoniated cleaners will craze acrylic (Vertical and Forming Grade).</p> <p>Over polishing may enhance scratches.</p>

Recommended Handling and Fabrication of Imagicor Polycarbonate & Acrylic Flexible Grade

Most of the fabrication techniques used for Designed Images' Imagicor flexible grade are similar to those when working with high pressure laminate. However, there are procedures unique to the material that are required to ensure a quality finished product.

Before fabrication inspect Imagecor material for damage from transit. In the event of questions concerning the material, note lot numbers prior to fabrication.

CUTTING

Due to its thickness, flexible grade can be cut to size with a variety of cutting equipment. However, we recommend a table/panel saw, with the appropriate saw blades as listed below. In both cases the material must be supported to prevent fluttering as it enters the blade. When using a table saw the table top must be free of burrs. Overlaying a piece of 1/8" Masonite® is advisable to prevent damage to the back of the material. Cutting the material with the backside up is also an option.

Saw blades used to cut Designed Images' Imagicor flexible grade are similar to cutting high-pressure laminate.

- 10" diameter blade should have a minimum of 80 teeth with a TCG tooth configuration and a 5-15 degree positive rake.
- 12" diameter blade should have a minimum of 100 teeth with a TCG tooth configuration and a 5-15 degree positive rake.

All blades should be carbide tipped, with a minimum blade clearance. Rip blades or blades with fewer teeth will tend to tear the material rather than cut it.

Preparation of the substrate is similar to substrates used with high-pressure laminate. The substrate's surface must be free of dust, oil, and release agents. The surface should not have the ability to transfer its surface characteristics to the flexible grade overlay. High quality substrates such as medium density fiberboard, no. 1 or Grade A 45 lb. Particleboard are recommended. Because the flexible grade material is thin, substrate roughness can telegraph to the surface. To ensure that telegraphing does not present a problem consideration is recommended in

Selecting the proper substrate surface.

Do NOT use sheet rock, gypsum board or any masonry product as a substrate to laminate Imagicor.

BONDING

Application of adhesive is not unlike applying adhesive to high-pressure laminate. Water based contact cement is the most preferred adhesive system, and commonly found in woodworking establishments. Method of adhesive application is important as in all overlay laminations. The contact cement should have a minimum of a 20% solid content. Application of adhesive should be dispensed in a light even pattern, avoiding heavy deposits. Allow the adhesive to dry thoroughly. **Not tacky to the touch. Please note that recommended dry times by the manufacturers of the adhesive are just what they mean, "Recommended". High humidity environments require longer open time than dry environments. The best test to determine if the adhesive surfaces are ready to laminate is "Dry to the Touch". Laminating before the adhesive is ready will cause solvent entrapment that will affect the strength of the bond and possible bleeding through to the surface of material.**

After applying the overlay to the substrate use a 3" "J" roller to create the proper bond between the two layers of the adhesive. Use a 3" "J" roller with medium body pressure to produce approximately 50 pounds of pressure per square inch. Less pressure will not ensure proper bonding of the two layers of adhesive. Six (6) or nine (9) inch "J" rollers are not recommended as the pressure applied is reduced by the size of the surface area of the rubber roller.

TRIMMING

Trimming the excess material is the same procedure and tooling as trimming high-pressure laminate. A standard laminate trimmer with a carbide flush-trim bit is recommended. A minimum of two flutes with pilot bearing is sufficient. Solid carbide, single flute flush-trim bit without a pilot bearing is not recommended due to risk of damaging the vertical plane of the flexible grade of Imagicor. Finish trimmed edges with a file, remembering to file in a downward motion into the surface of the material.

Recommended Handling and Fabrication of Imagitor Polycarbonate & Acrylic Flexible Grade

CLEANING

The cleaning agent that is readily available to remove adhesive over spray is Mineral Spirits. **Solvents such as contact adhesive solvent, acetone, paint thinner, lacquer thinner etc. are not recommended. Use of these solvents will immediately attack the surface of Designed Images' Imagitor, which will not be repairable.** To remove the oily residue left from the mineral spirits, window cleaners **without Ammonia** can be used.

MAINTENANCE

Care and cleaning of Imagitor is not difficult, providing one uses the proper cleaning agents. Use only soft cotton clothes (old tee shirts, diapers, etc.) with agents such as vinegar base window cleaners. **Paper towels** are not recommended, as paper contains micron particles of sand that could damage the surface of the material.

There are commercial acrylic cleaner/polishes available on the market; and many have anti-static agents to minimize static cling.

Superficial scratches can be removed from the surface of Imagitor by using the proper plastic polishes and procedures.

If you have any additional questions concerning the fabrication of Designed Images' Imagitor flexible grade, or further explanation of the above content, you may contact:

Designed Images
440-708-2526

RECOMMENDED CLEANING AND POLISHING PRODUCTS

Cleaner Polishes:

Kano "Glit"
Kano Laboratories
Nashville, TN 37211
615-833-4101

Kleenmaster Brilliantize
Manufactured by Chemical Products
Company, Omaha, Nebraska 68102

Scratch & Scuff Repair:

Novus #1 and #2
Manufactured by Novus Inc.,
Minneapolis, MN 55438
1-800-548-6872

Specifications

PROPERTY	STANDARD	DESIGNED IMAGES' <i>Imagitor</i> GRADES			
		.118" Acrylic ±.012"	.060" Acrylic ±.006"	.060 Polycarbonate ±.006"	.030 Polycarbonate ±.003
Bending when proper heat applied					
Hot Bending		Not rated	6" radius	Not rated	Not rated
Cold Bending		18" radius	9" radius	6" radius	3" radius
Impact (test conducted on <i>Imagitor</i> laminated to particleboard)					
.25 lb. Steel ball	NEMA LD3-3.8	36"	---	<8"	<8"
.50 lb. Steel ball		12"	<10"	<10"	<10"
Stain Resistance	NEMA LD3-3.4	No effect from any reagents test except: Acetone Amyl Acetate (Nail Polish Remover) Lacquer Thinner Toluene			
Light Stability	NEMA LD3-3.3	No effect	No effect	No effect	No effect
Dimensional Change	NEMA LD3-3.11	No effect	No effect	No effect	No effect
Coefficient of Thermal Expansion	ASTM E228	4.0 x 10 ⁻⁵ in/in/F		3.75 x 10 ⁻⁴ in/in/F	
High Temperature Resistance	NEMA LD3-3.6	Severe surface disturbance to all grades.			
Radiant Heat Resistance	NEMA LD3-3.7	(cigarette at <60 seconds) Moderate surface disturbance to all grades.			
Abrasion Resistance					
Using Taber Abrasion 100 Revolutions (CS10F Wheel 500gm)		50%	(% equals increase in haze)		50%
		50%	50%	50%	50%
Hand Rubbed Steel Wool		(Using five strokes with moderate pressure)			
		Severe	Severe	Severe	Severe
<p>Note: It is inherent in the manufacturing of methacrylate sheets that slight surface imperfections may exist. All <i>Imagitor</i> sheets meet or exceed federal specifications LP-391-D Type III.</p>					